



INSTRUCTION DE MONTAGE
MONTAGEANLEITUNG
INSTRUCTIONS FOR ASSEMBLY
INSTRUCCIONES DE MONTAJE

WIDOOR

2 x 50 KG

PORTE D'INTÉRIEUR À MOTORISER
INNENTÜR MIT ELEKTRO-ANTRIEB
INTERIOR AUTOMATIC DOOR
PUERTA DE INTERIOR MOTORIZADA

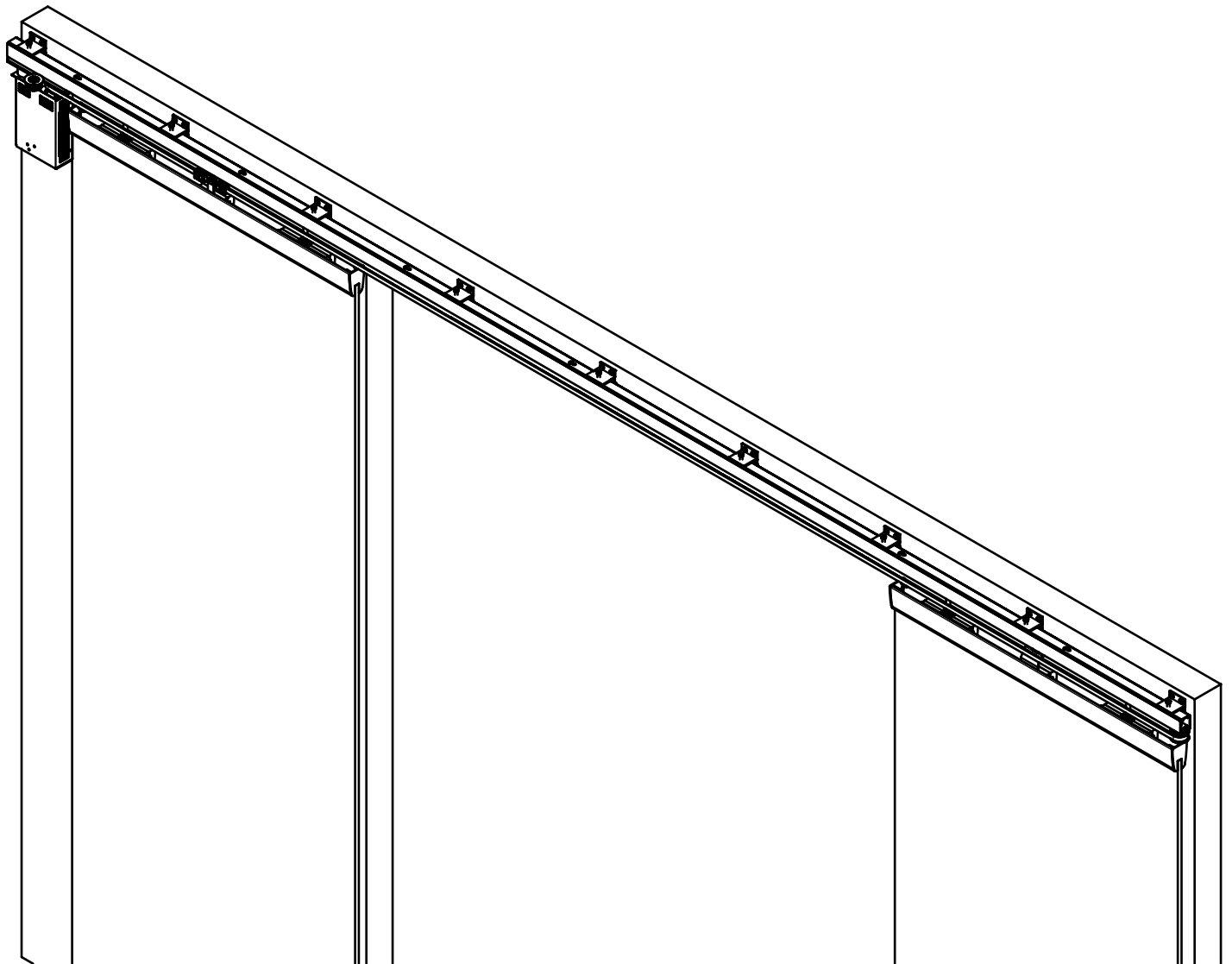

COMPOSITION - ZUSAMMENSETZUNG - COMPOSICIÓN

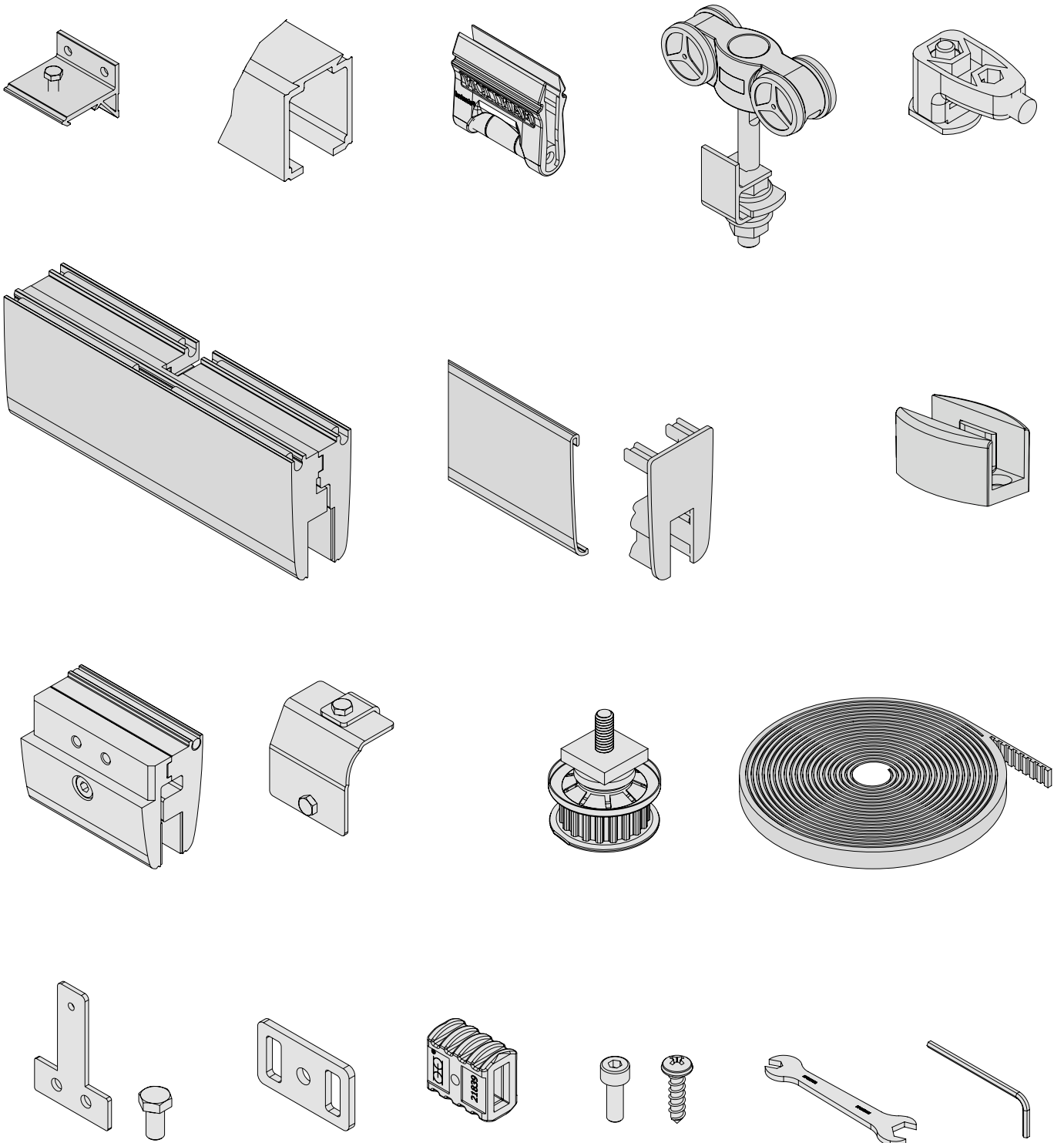

CONDITIONS DE POSE / MONTAGEBEDINGUNGEN / INSTALLATION REQUIREMENTS / CONDICIONES DE COLOCACION:

- Produit destiné à une utilisation en intérieur / Dieses Produkt ist nur für Innenanwendung geeignet / For indoor use only / Producto para utilización en interior
- Ne pas installer dans des endroits humides / Nicht in feuchten Atmosphären verwenden / Do not install in humid places / No instalar en lugares húmedos
- Le montage doit être effectué par des monteurs qualifiés / Die Montage muss von qualifizierten Handwerkern geführt werden / Installation must be performed by skilled personnel / el montaje tiene que hacerse por instaladores cualificados

OUTILLAGE NÉCESSAIRE A LA POSE / BENÖTIGTE WERKZEUGE / REQUIRED TOOLS FOR ASSEMBLY / HERRAMIENTA NECESARIA PARA LA COLOCACIÓN:

- Mètre / Metermass / Measuring tape / Flexometro
- Visseuse/perceuse à percussion (selon type de support) / Einschraubmaschine / Schlagbohrer (je nach dem Wandmaterial) / Percussion drill (if needed) / Atornillador / taladro de percusión (en función del soporte)
- Niveau à bulle / Wasserwaage / Spirit level / Nivel de burbuja
- Clés BTR de 3 et 4 / Schlüssel / Allen wrenches (3 and 4 mm) / Llave Allen de 3 y 4

DIMENSIONS / MASSE / SIZING / DIMENSIONES (mm):

Ecoinçon min. côté moteur / Min. Eckenmasse auf Stauplatzseiten / Min. nook for pushback side / Rincón min. Lado retroceso : **O/2 + 180 mm (WIDOOR INSIDE)**
O/2 + 200 mm (WIDOOR)

Ecoinçon min. / Min. Eckenmasse / Min. nook / Rincón min. : **O/2 + 50 mm**

Linteau min. / Min. Türsturz / Min. lintel / Dintel min: **120 mm**

Hauteur du panneau / Paneelhöhe / Panel height / Altura del panel: **H - 25 mm**

Largeur panneau / Paneelbreite / Panel width / Anchura del panel: **O/2 + 35 mm**

Epaisseur panneau / Paneelstärke / Panel thickness / Grueso del panel: **8-10mm**

Poids panneau / Paneelgewicht / Panel weight / Peso panel: **2 x 50 Kg MAX**

Caractéristiques alimentation / Versorgung / Power supply output current rate / Características de la alimentación: **24V AC/DC 2.5A (WIDOOR INSIDE)**
230 V AC (WIDOOR)

WIDOOR INSIDE

Le moteur peut être situé à gauche ou à droite
Motorization can be on the left or right side

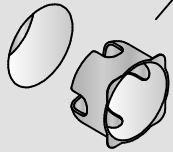
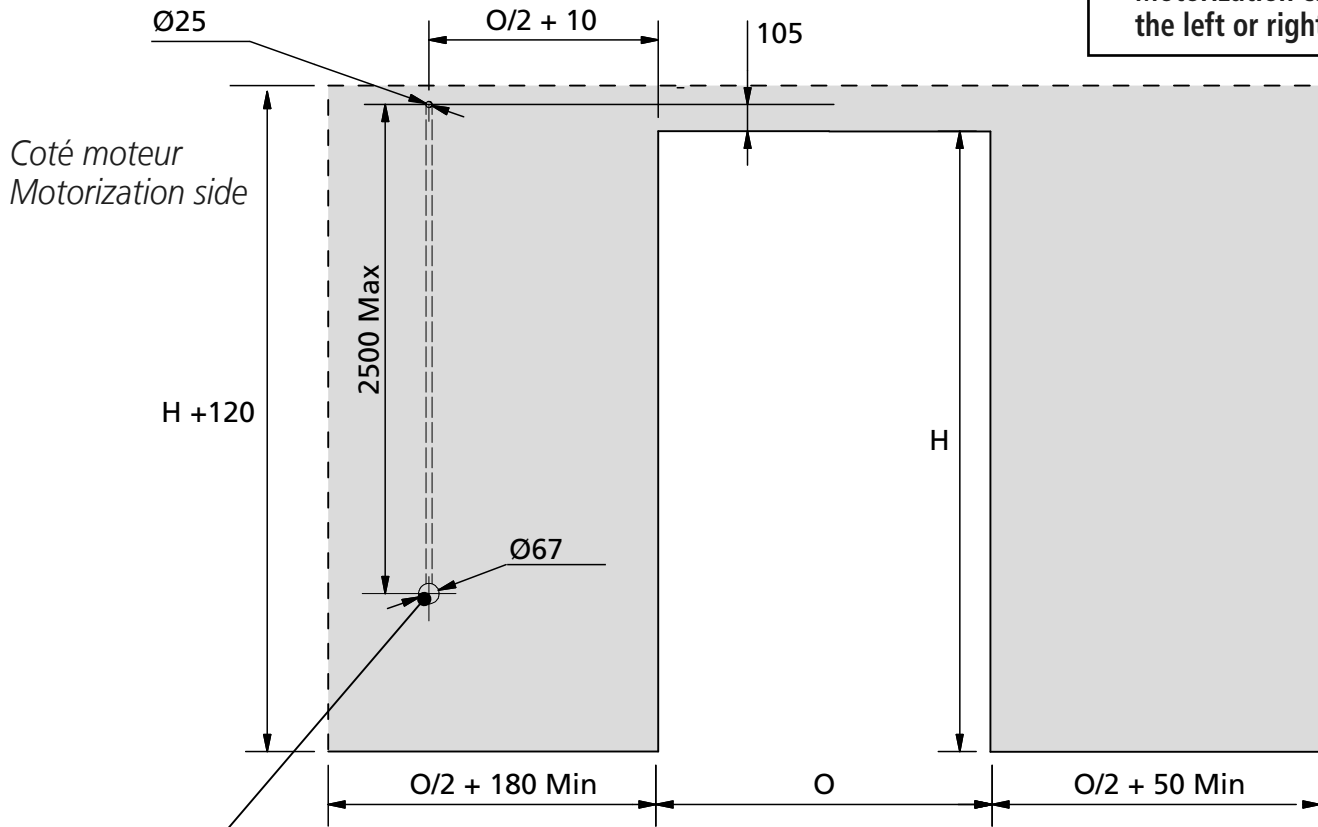

IMPORTANT: le boîtier de gestion doit être toujours accessible pour les opérations de réglage et les éventuelles interventions qui pourraient se rendre nécessaires.
WICHTIG: die Steuerungseinheit muss für Einstellungen sowie Wartungsarbeit immer zugänglich sein.
WARNING: the electronic board must be accessible for any further setting operation

WIDOOR

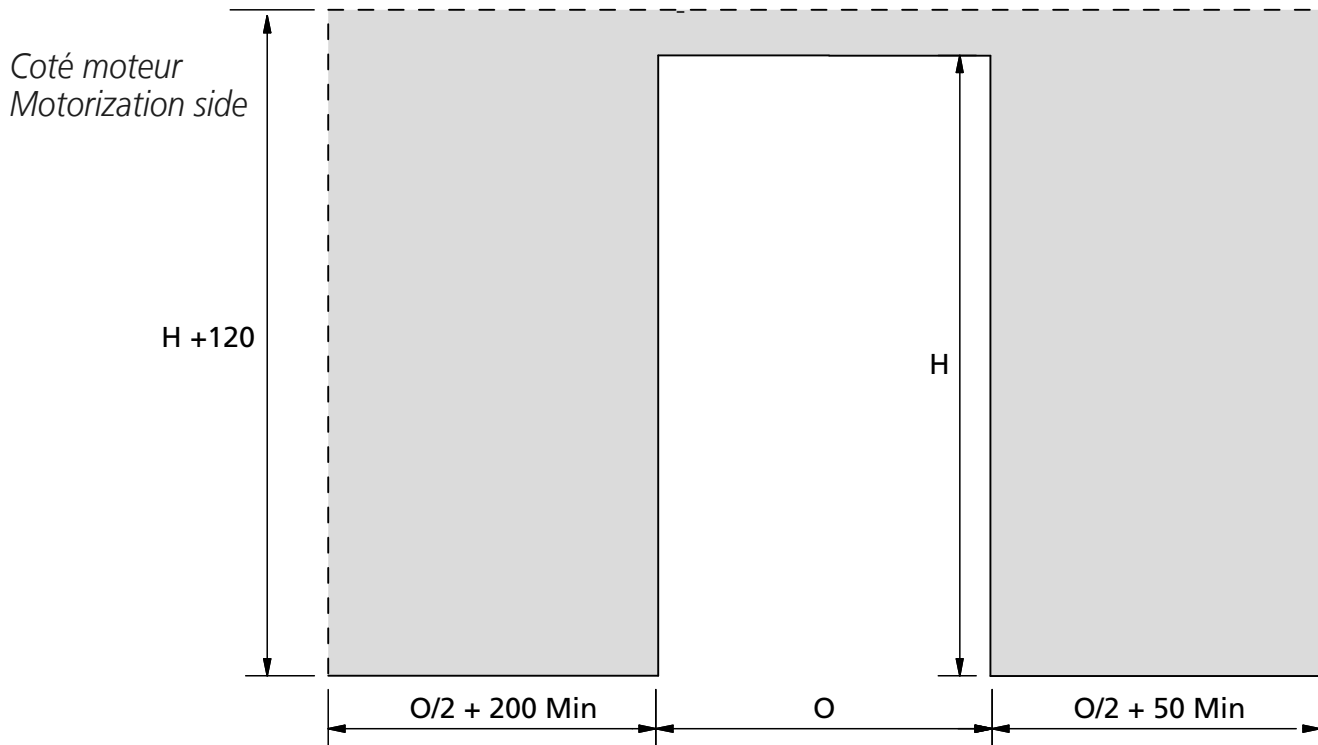

INSTALLATION / MONTAGE / ASSEMBLY / MONTAJE

1.

a

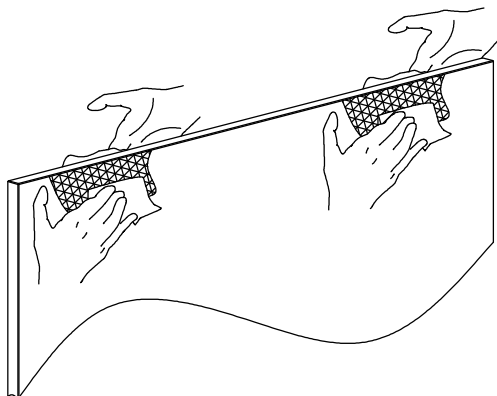

$L = O/2 + 35 \text{ mm}$
 $W = H - 25 \text{ mm}$

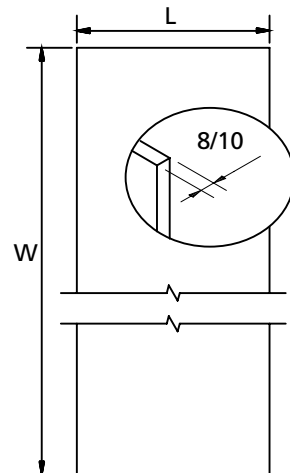

Face 1



b

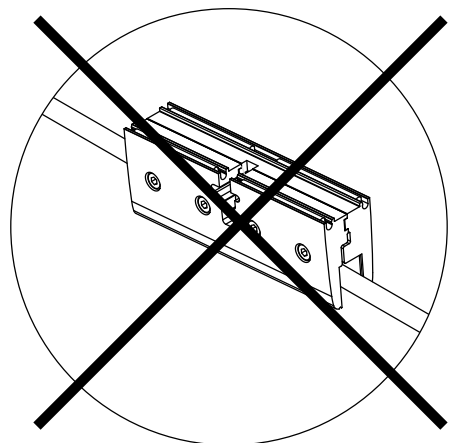
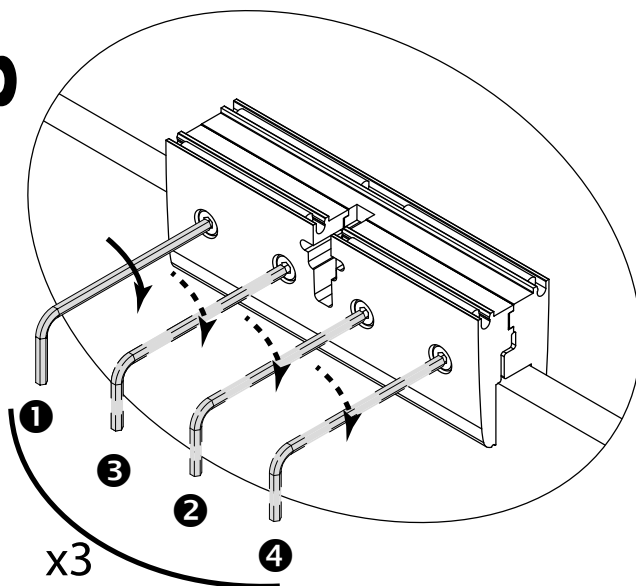

75

9 N.m

Face 1

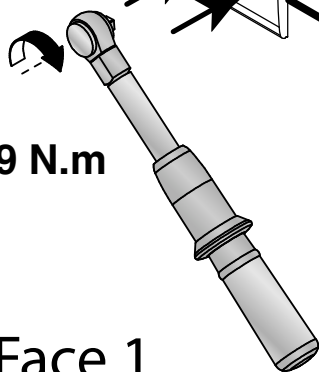

180°

L/2

75

x 2

2.

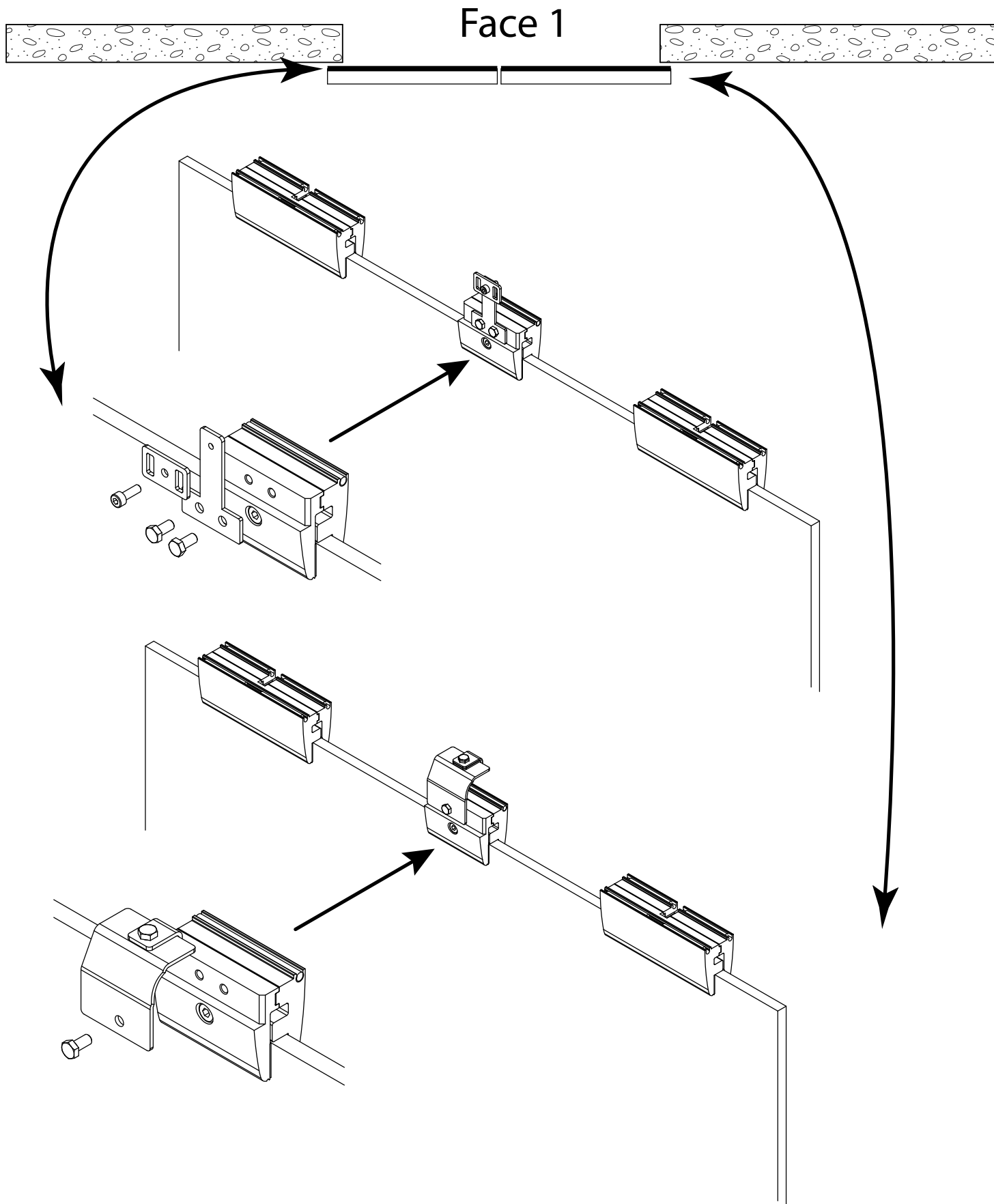

INSTALLATION / MONTAGE / ASSEMBLY / MONTAJE

3.

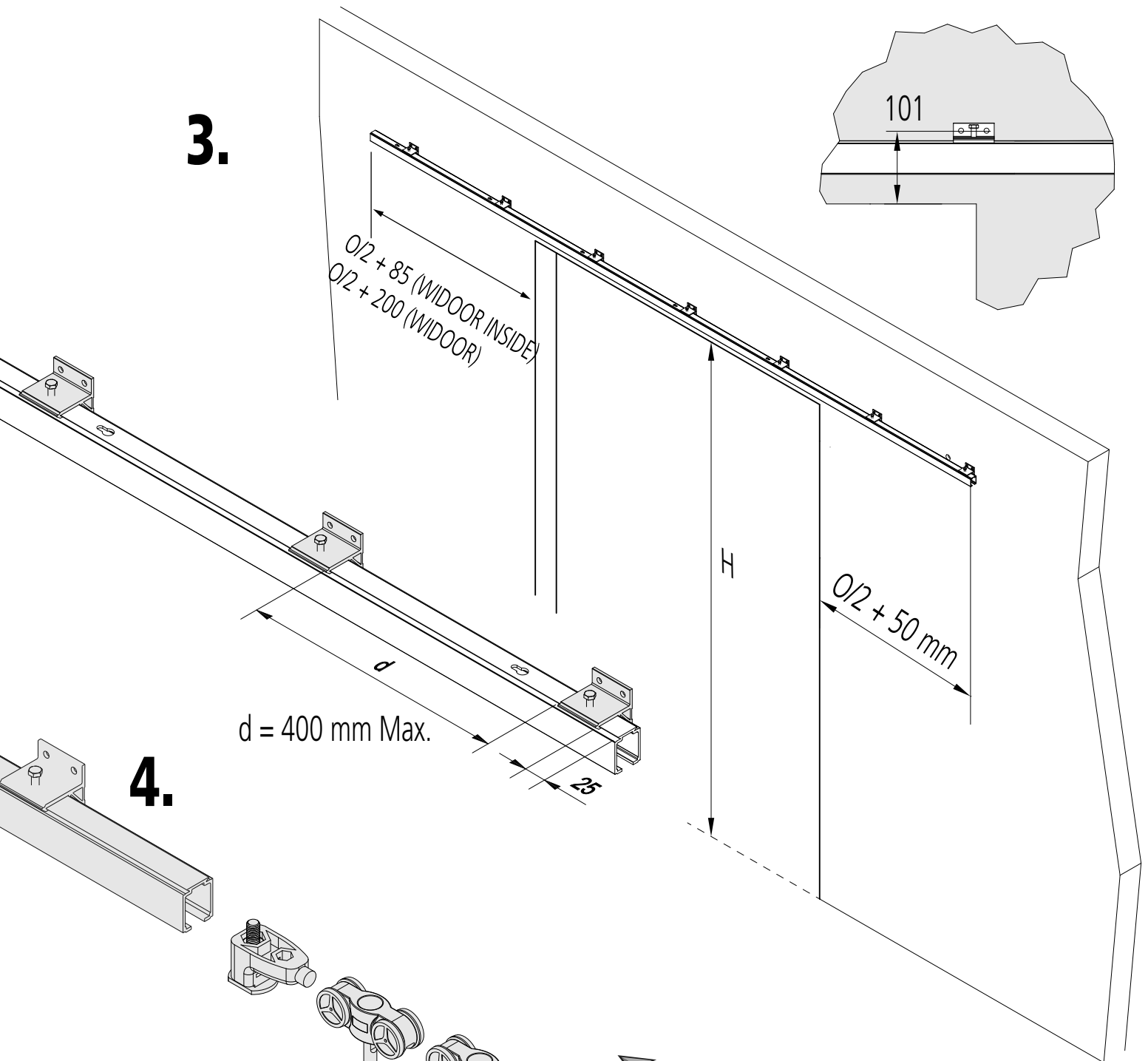

4.

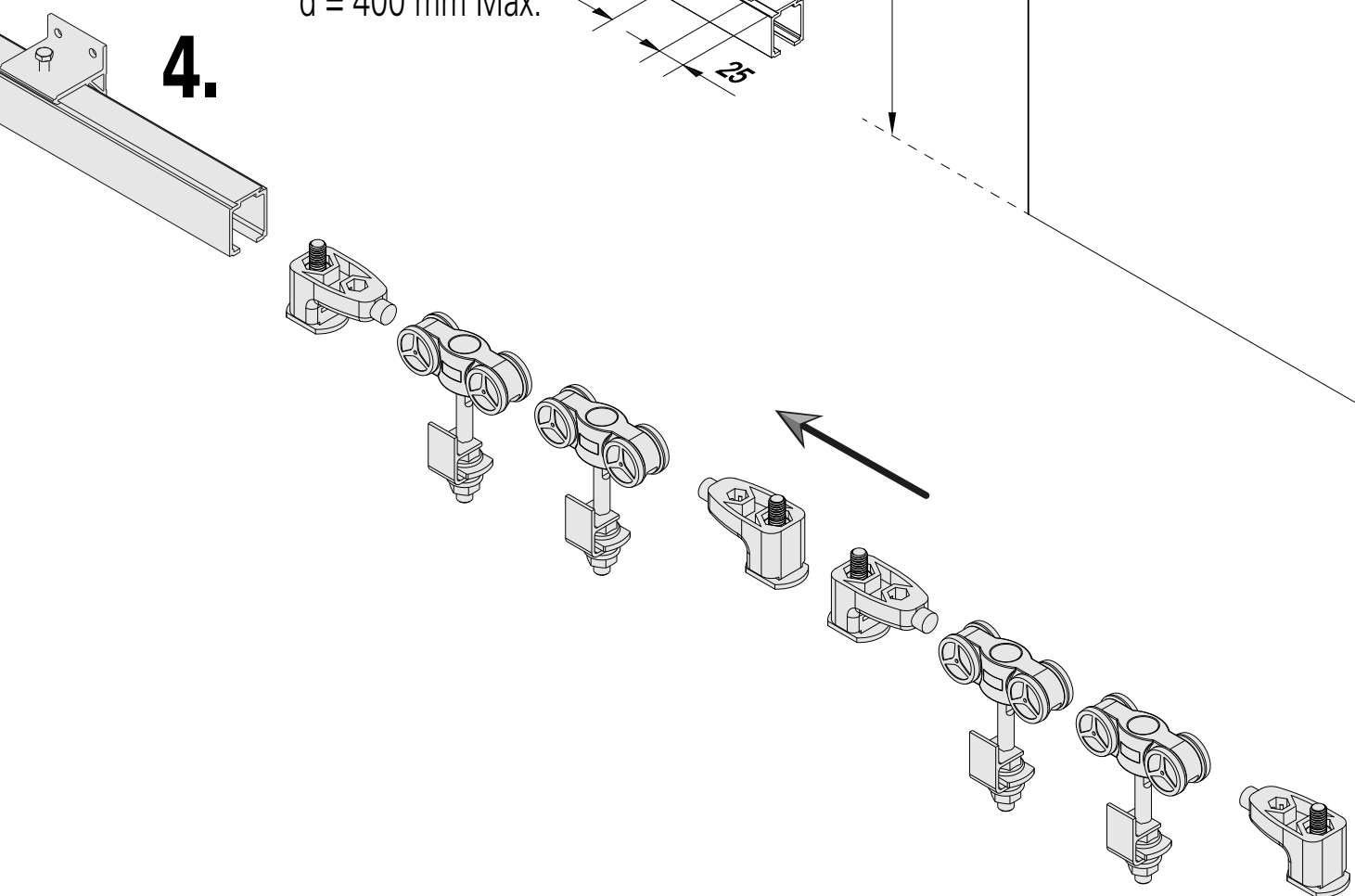

5.

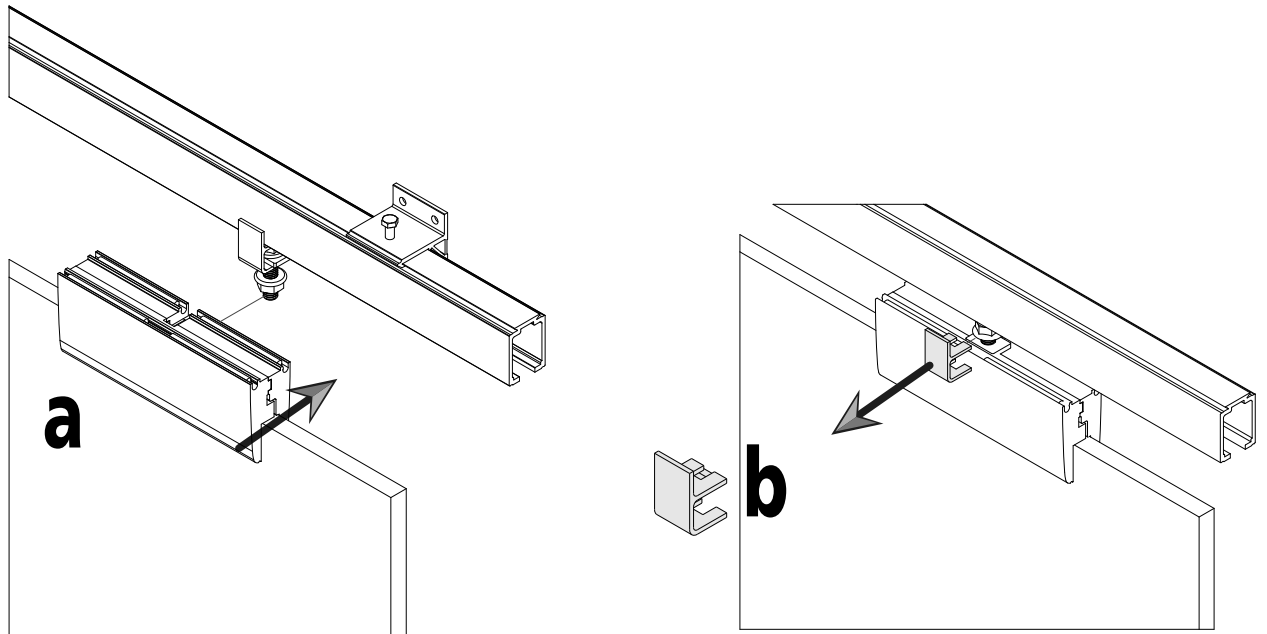

6.

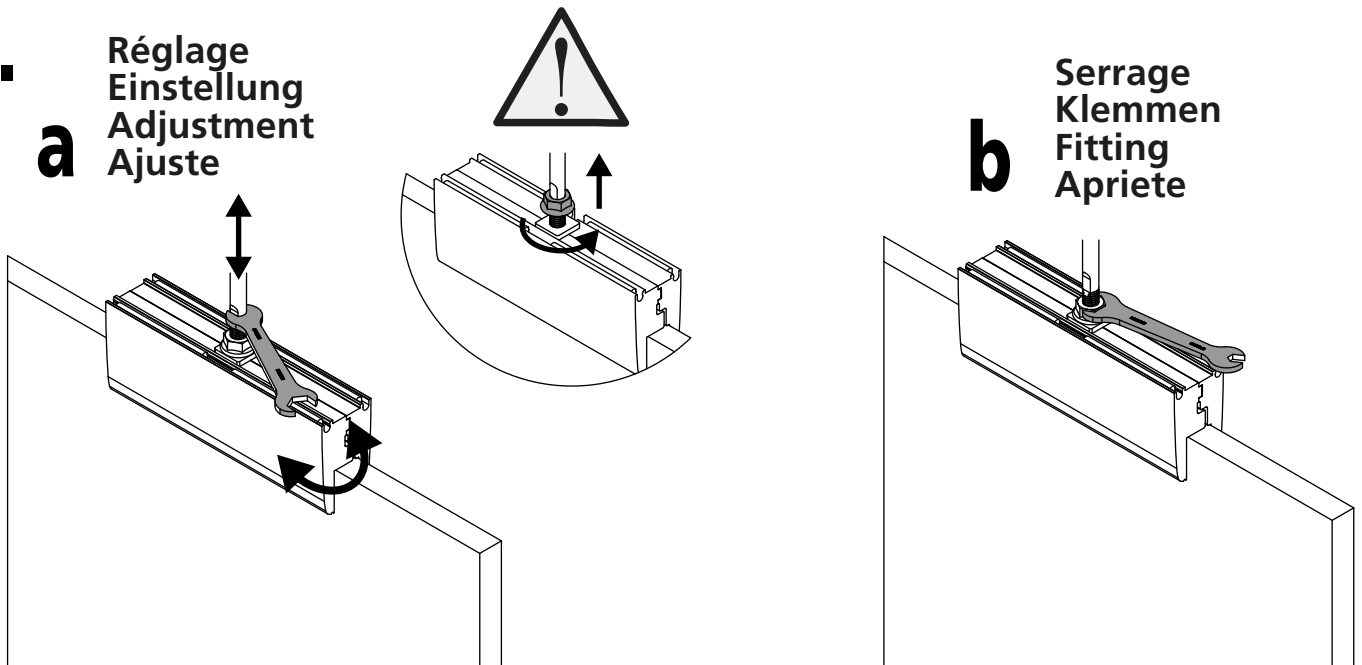

7.

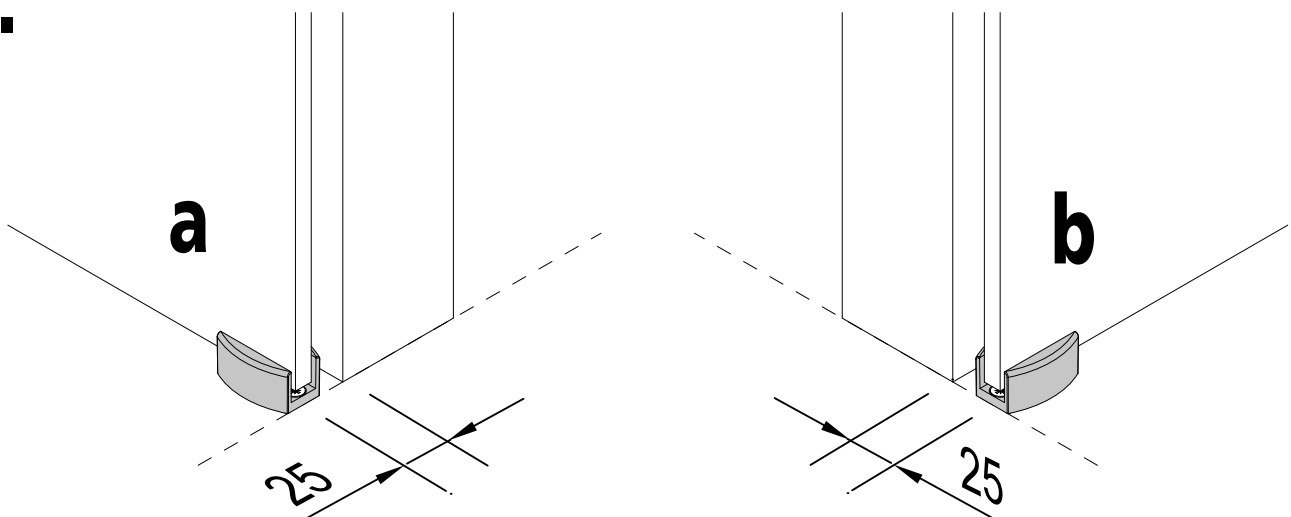

8.

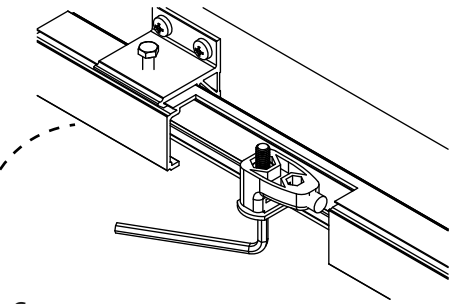

Serrage
Klemmen
Fitting
Apriete

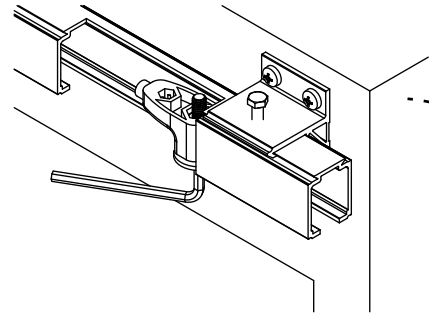
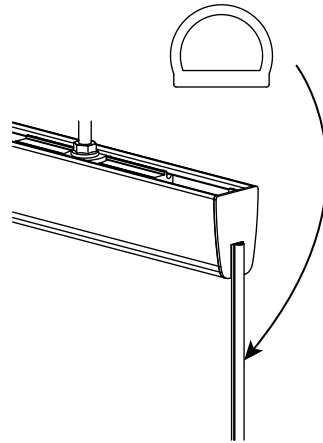

Serrage
Klemmen
Fitting
Apriete

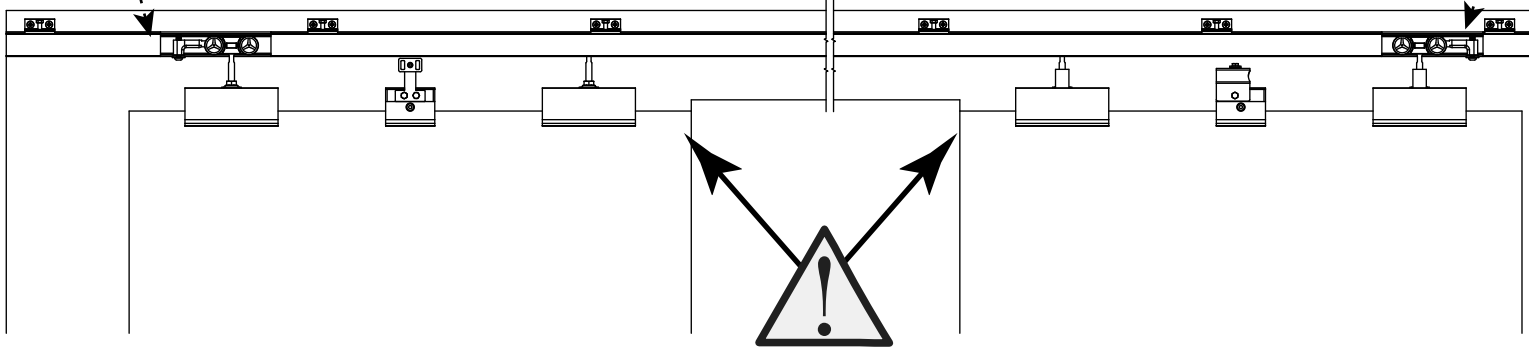

Serrage
Klemmen
Fitting
Apriete

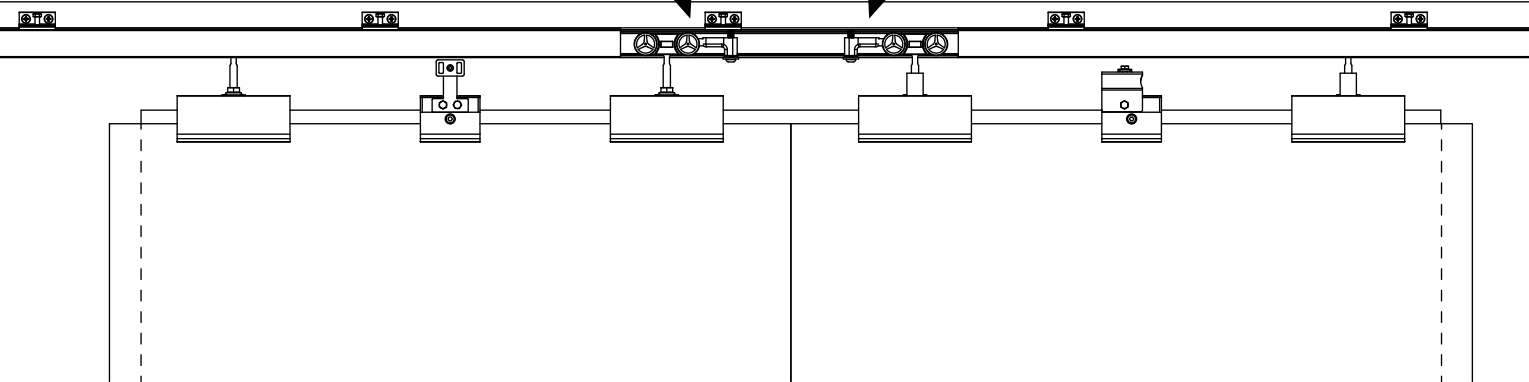

//

9.

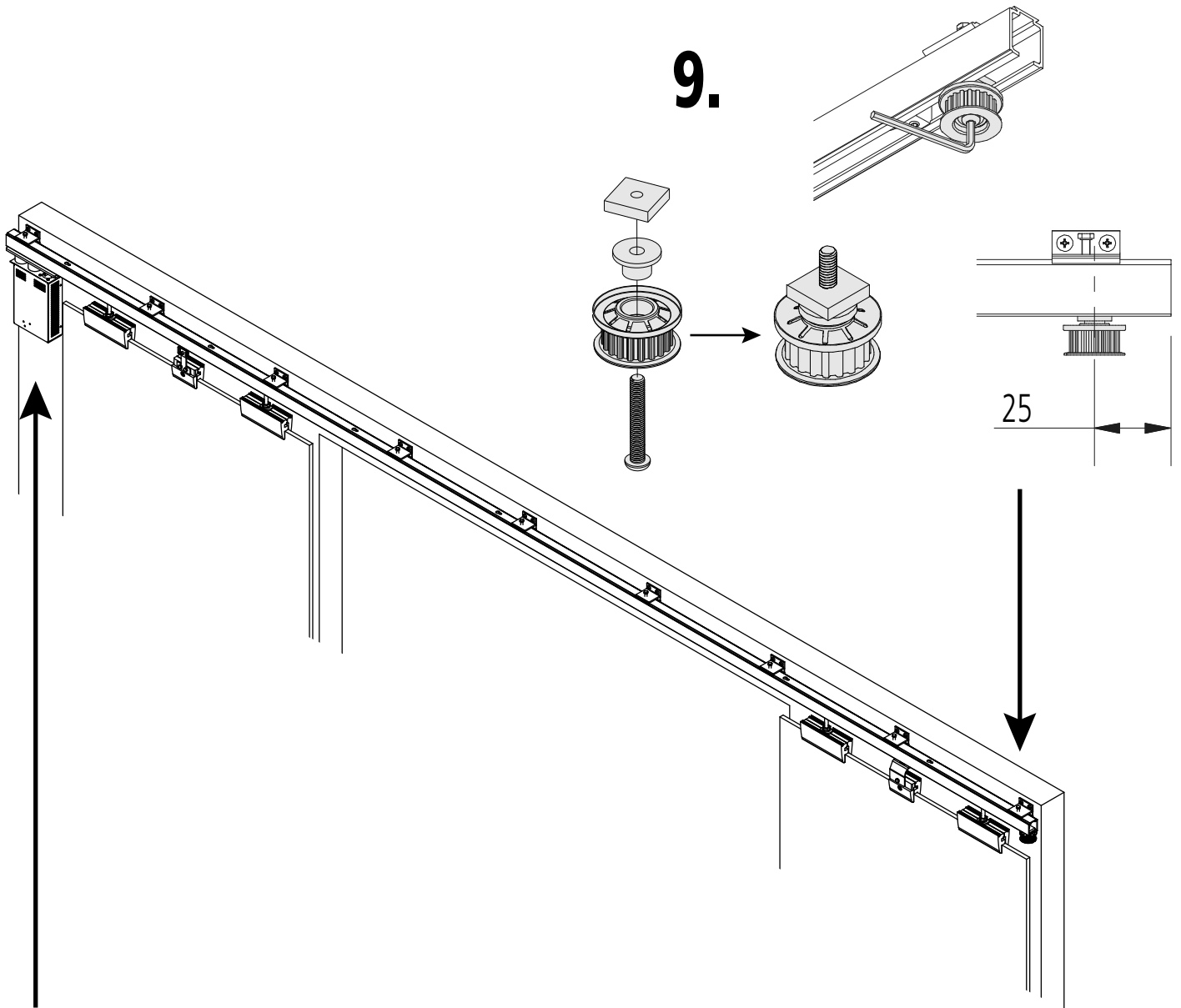

10.

WIDOOR INSIDE

WIDOOR

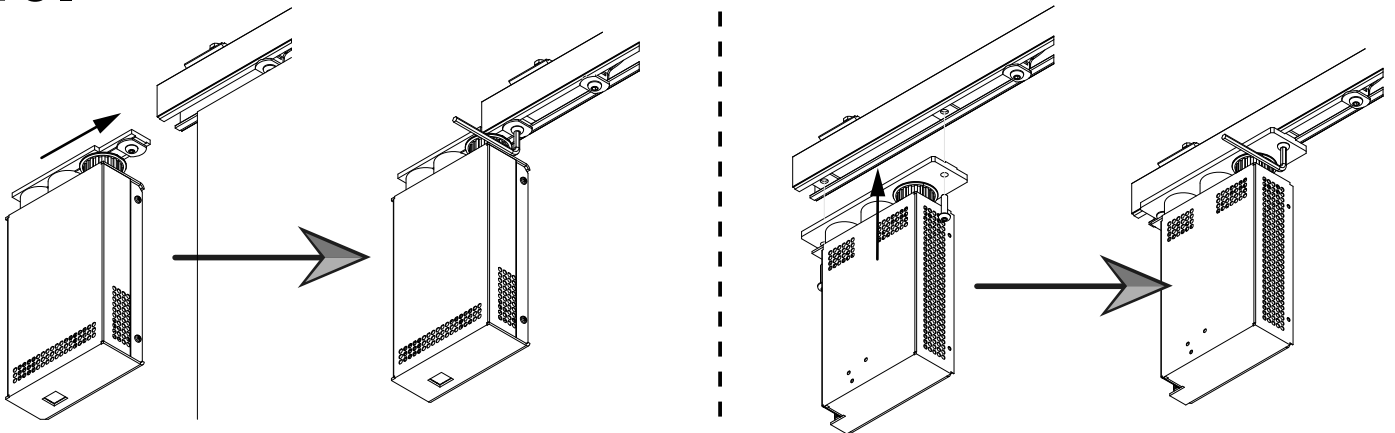

11.



Le montage de la courroie doit impérativement se faire : porte en position ouverte ou fermée
 Die Montage des Riemens soll unbedingt mit geöffneter / oder geschlossener Tür kommen
 The assembly of the belt necessarily has to be made with opened / or closed door.
 El montaje de la correa tiene que hacerse imperativamente con puerta en posición abierta o cerrada

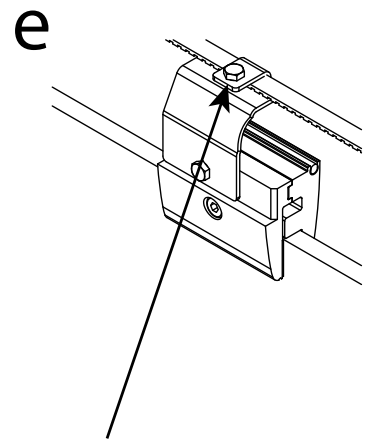
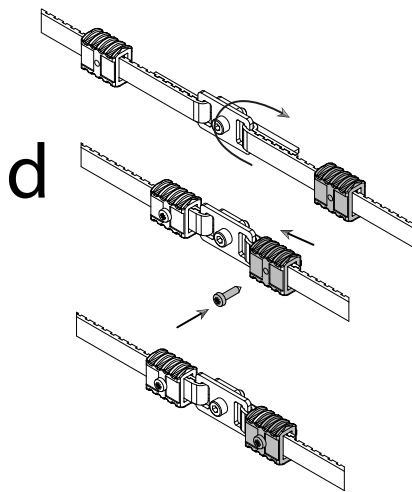
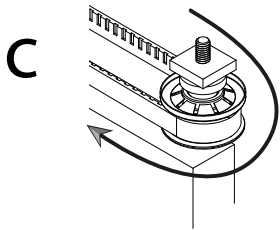
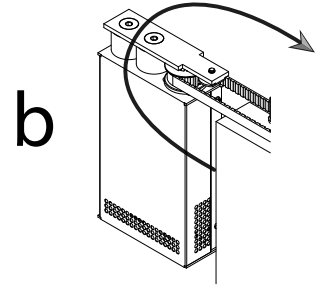
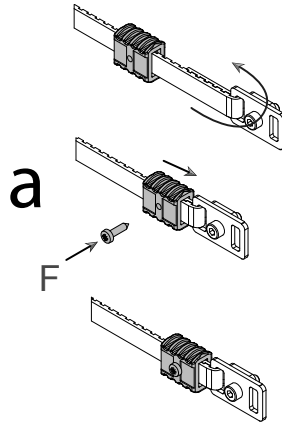

Serrage
 Klemmen
 Fitting
 Apriete

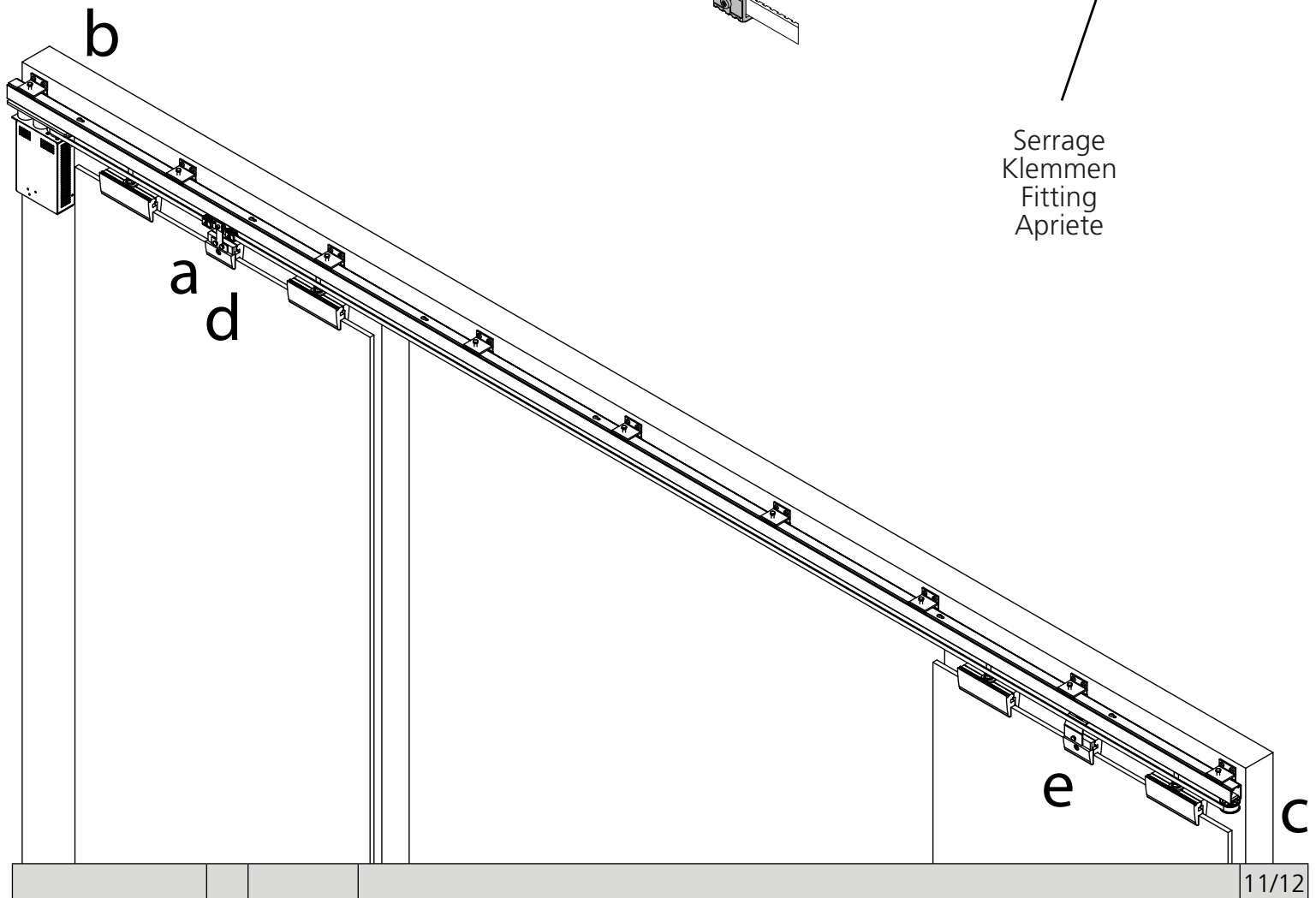

INSTALLATION / MONTAGE / ASSEMBLY / MONTAJE

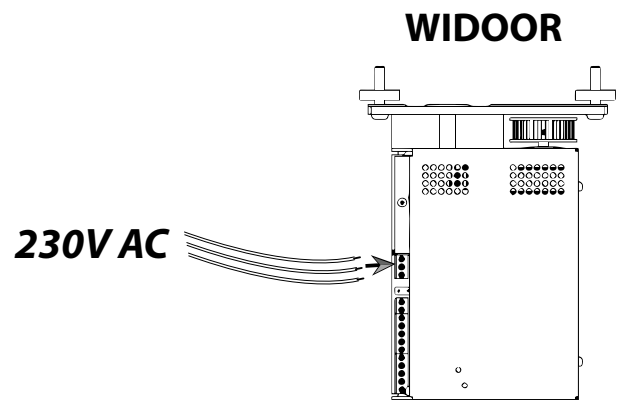
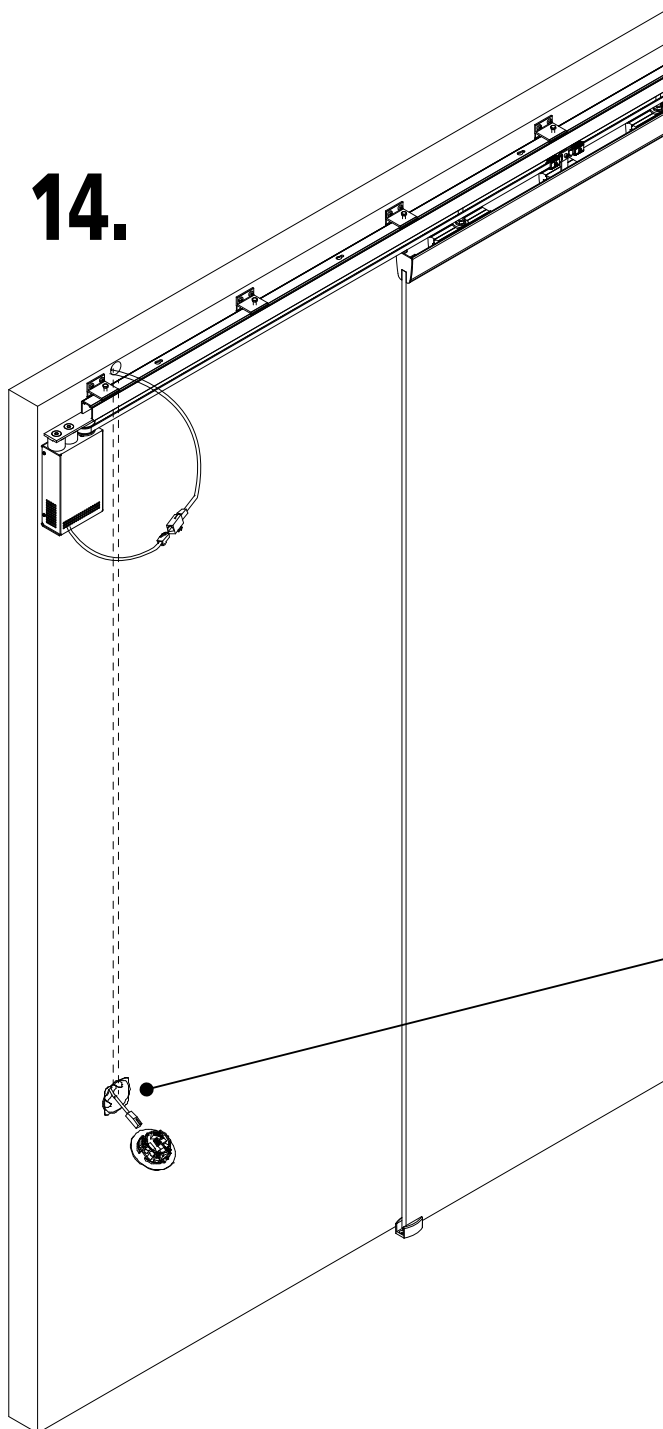
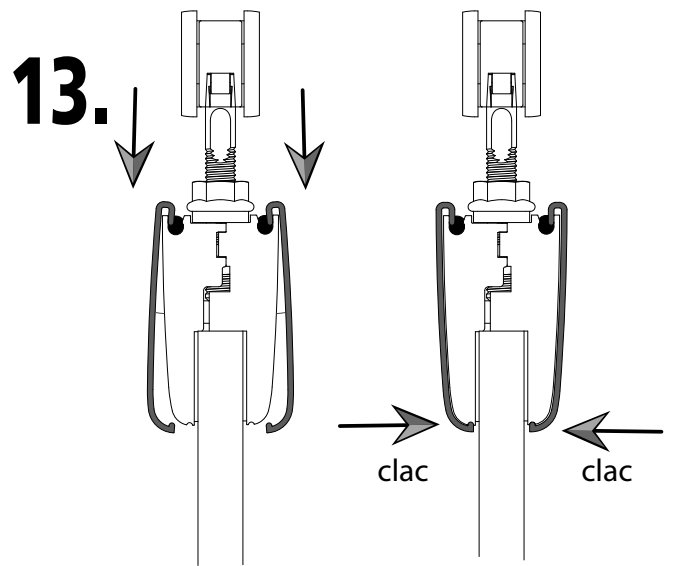
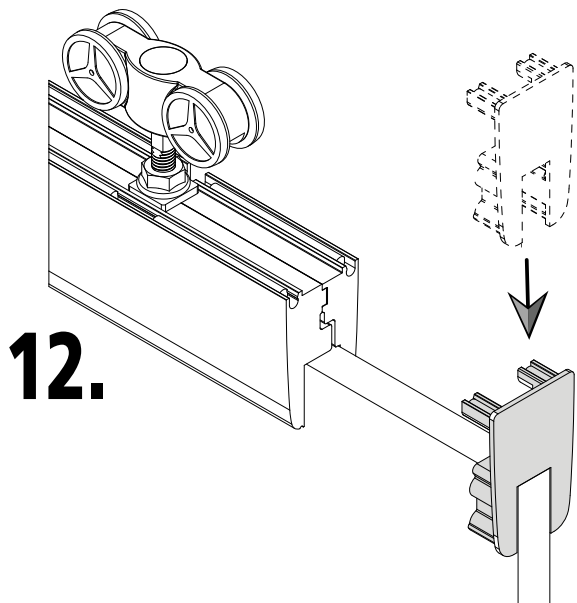

WIDOOR INSIDE

